

The S/PTCU-20/X is a 20 gpm portable contaminant removal system for use in both above- and below-ground fuel storage tanks. It is designed specifically to remove water and other heavy contaminants common to stored diesel fuel. Options include: bag filter for sludge removal, high-efficiency fuel filter, three-phase fuel coalescer with a 99.5% single-pass water removal efficiency, and power upgrades.

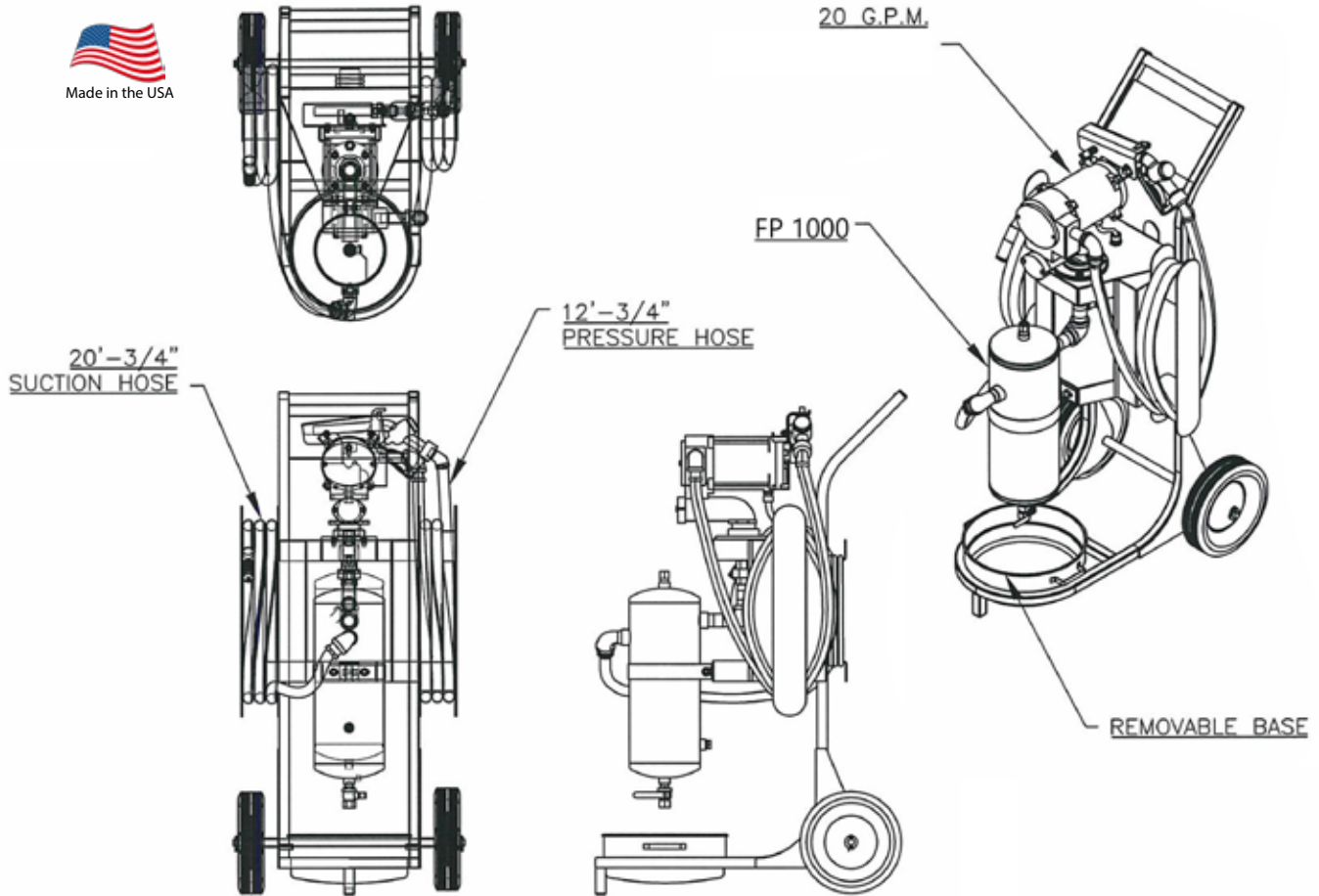

### Product Details

<b>Product Line</b>	Portable Tank Cleaning Unit
<b>Model</b>	S/PTCU-20/X
<b>Dimensions</b>	50" H x 22" W x 31" D
<b>Weight</b>	approximately 200 lbs.

### Pump and Motor

<b>Standard Power</b>	115VAC, 50 or 60 Hz, Single Phase
<b>Power Upgrade</b>	220VAC, 50 or 60 Hz, Single Phase
<b>Motor Horse Power</b>	1/3 hp
<b>Motor Operation</b>	Self-Priming, Explosion-Proof Motor
<b>Max. Operating Pressure</b>	78 psi
<b>Pump Horse Power</b>	1/3 hp
<b>Pump Operation</b>	Portable, Explosion-Proof
<b>Nominal Flow</b>	20 gpm

### The Fuel Purifier

<b>Model Number</b>	TFP 1000
<b>Nominal Flow</b>	20 gpm
<b>Water Drain Port</b>	1/2"
<b>Free Water Removal</b>	up to 99.8%
<b>Contaminant Removal</b>	up to 95%

### Hoses

<b>Foot Suction Hose</b>	20' x 3/4" - Explosion-Proof
<b>Foot Pressure Hose</b>	12' x 3/4"
<b>Manual Shut-Off Nozzle</b>	3/4"

### Optional Filtration

<b>Three-Phase Coalescer</b>	5 micron
<b>Emulsified Water Removal</b>	99.5% Single-Pass Water Removal
<b>High-Efficiency Fuel Filter</b>	3 micron

### Additional Features

- 90-Degree Swivel Couplings
- 25' Power Cord
- Removable Drip Pan
- One Year Manufacturer's Warranty on pump
- Optional: Bag Filter, High-Efficiency Fuel Filter, Three-Phase Fuel Coalescer

