

Portable Tank Cleaning Unit

S/PTCU-25/X

The S/PTCU-25/X is a 25 gpm portable contaminant removal system for use in both above- and below-ground fuel storage tanks. It is designed specifically to remove water and other heavy contaminants common to stored diesel fuel. Options include: bag filter for sludge removal, high-efficiency fuel filter, three-phase fuel coalescer with a 99.5% single-pass water removal efficiency, and power upgrades.

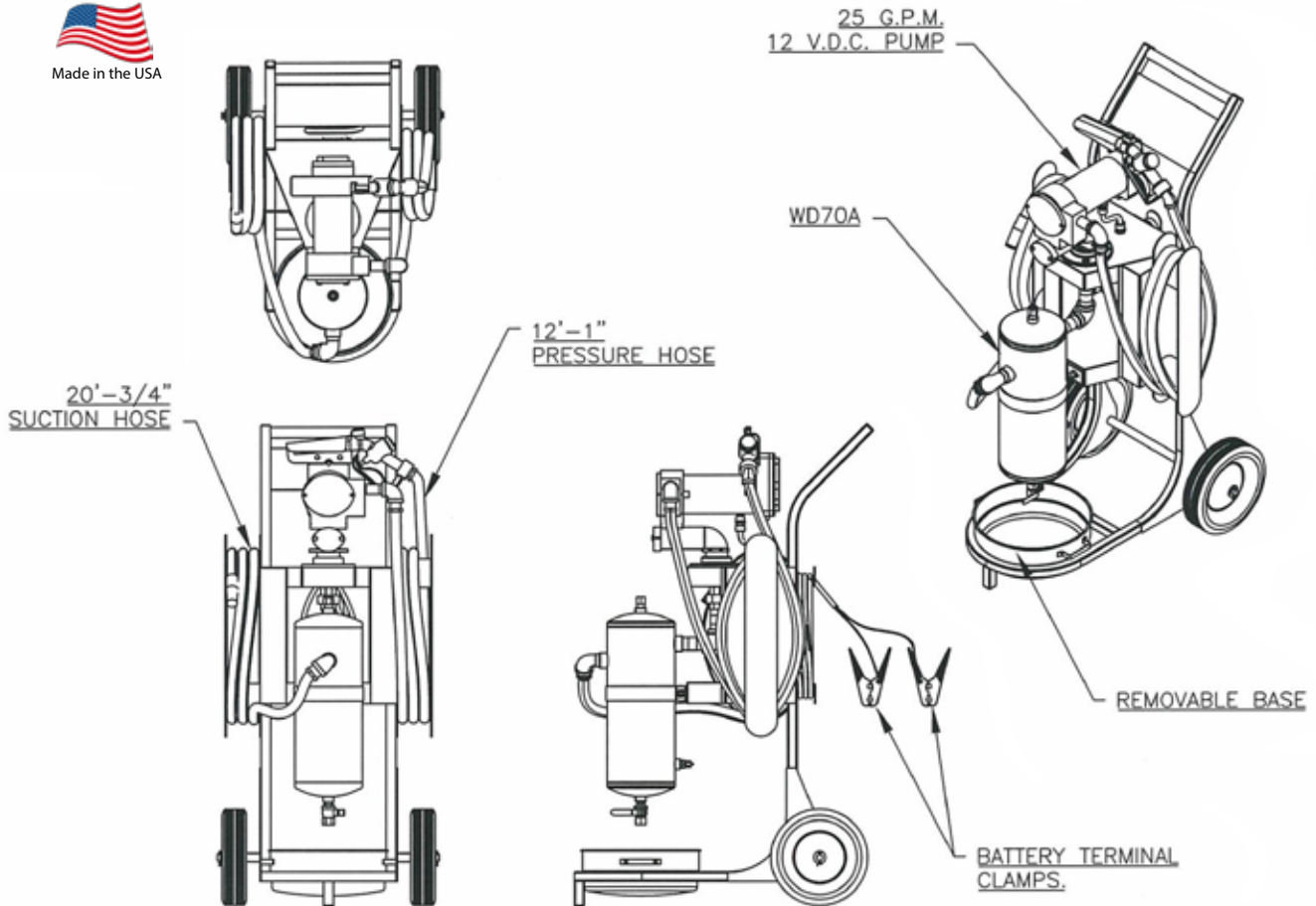

Product Details

Product Line	Portable Tank Cleaning Unit
Model	S/PTCU-25/X
Dimensions	50" H x 22" W x 31" D
Weight	170 lbs.

Pump and Motor

Standard Power	12/24 VDC, 50 or 60 Hz, Single Phase
Motor Horse Power	1/3 hp
Motor Operation	Self-Priming, Explosion-Proof Motor
Max. Operating Pressure	78 psi
Pump Horse Power	1/3 hp
Pump Operation	Portable, Explosion-Proof
Nominal Flow	25 gpm

The Fuel Purifier

Model Number	TFP 1000
Nominal Flow	25 gpm
Water Drain Port	1/2"
Free Water Removal	up to 99.8%
Contaminant Removal	up to 95%

Hoses

Foot Suction Hose	20' x 3/4" - Explosion-Proof
Foot Pressure Hose	12' x 1"
Manual Shut-Off Nozzle	3/4"

Optional Filtration

Three-Phase Coalescer	5 micron
Emulsified Water Removal	99.5% Single-Pass Water Removal
High-Efficiency Fuel Filter	3 micron

Additional Features

- 90-Degree Swivel Couplings
- 25' Power Cord
- Removable Drip Pan
- One Year Manufacturer's Warranty on pump
- Optional: Bag Filter, High-Efficiency Fuel Filter, Three-Phase Fuel Coalescer

