

The S/PTCU-50/X is a 50 gpm high-volume portable contaminant removal system for use in both above- and below-ground fuel storage tanks. It is designed specifically to remove water and other heavy contaminants common to stored diesel fuel. Options include: bag filter for sludge removal, high-efficiency fuel filter, three-phase fuel coalescer with a 99.5% single-pass water removal efficiency, and power upgrades.

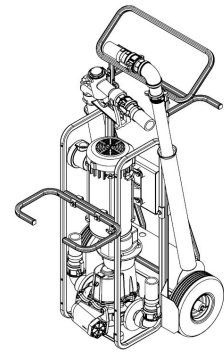

NOTE: Fuel purifier and hoses not shown on drawing. See photograph below.

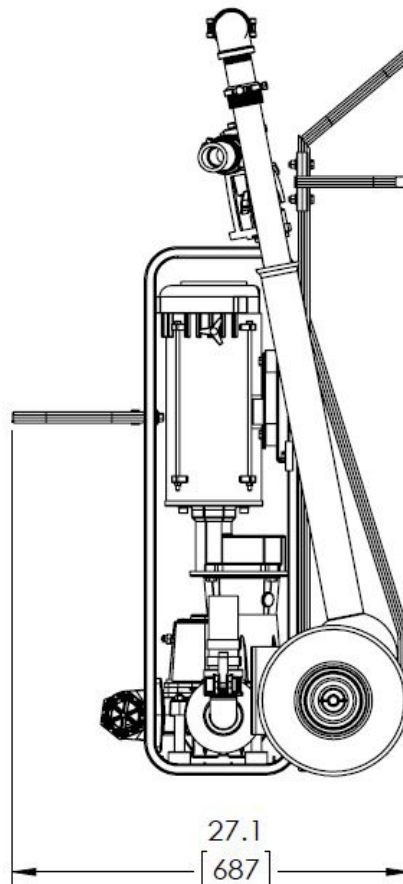
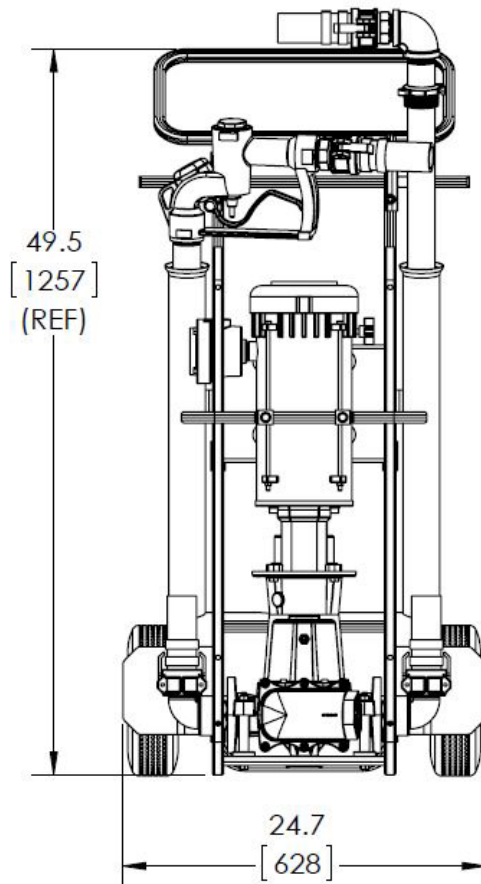

**Product Details**

<b>Product Line</b>	Portable Tank Cleaning Unit
<b>Model</b>	S/PTCU-50/X
<b>Dimensions</b>	50" H x 25" W x 31" D
<b>Weight</b>	305 lbs.

**Pump and Motor**

<b>Standard Power</b>	115/230VAC, 60 Hz, Single Phase 14.4 FLA @ 120VAC
<b>Motor Horse Power</b>	1.5 hp
<b>Motor Operation</b>	Self-Priming, Explosion-Proof Motor
<b>Max. Operating Pressure</b>	78 psi
<b>Pump Horse Power</b>	1.5 hp
<b>Pump Operation</b>	Positive-Displacement Transfer Pump
<b>Pump Head</b>	1.5" Blade Master

**The Fuel Purifier**

<b>Model Number</b>	TFP 1500
<b>Nominal Flow</b>	50 gpm
<b>Water Drain Port</b>	1"
<b>Free Water Removal</b>	up to 99.8%
<b>Contaminant Removal</b>	up to 95%

**Hoses**

<b>Suction Hose</b>	1-1/2" x 10' - Explosion-Proof
<b>Pressure Hose</b>	1-1/2" x 10' - Explosion-Proof
<b>Manual Shut-Off Nozzle</b>	1-1/2"

**Optional Filtration**

<b>Three-Phase Coalescer</b>	5 micron
<b>Emulsified Water Removal</b>	99.5% Single-Pass Water Removal
<b>High-Efficiency Fuel Filter</b>	3 micron

**Additional Features**

- 1.5" Manual Shut-Off Nozzle
- 90-Degree Swivel Couplings
- 50' Power Cord
- 4' Aluminum Suction Tube
- Quick-Release Aluminum Cam Lock Couplings
- One Year Manufacturer's Warranty on pump
- Optional: Bag Filter, High-Efficiency Fuel Filter, Three-Phase Fuel Coalescer

