

Portable Tank Cleaning Unit

S/PTCU-8/X

The S/PTCU-8/X is an 8 gpm portable contaminant removal system for use in both above- and below-ground fuel storage tanks. It is designed specifically to remove water and other heavy contaminants common to stored diesel fuel. The standard system operates on 12 VDC power and is lightweight enough for one-person handling and operation. The system is designed for easy storage and does not utilize a filter or moving parts.

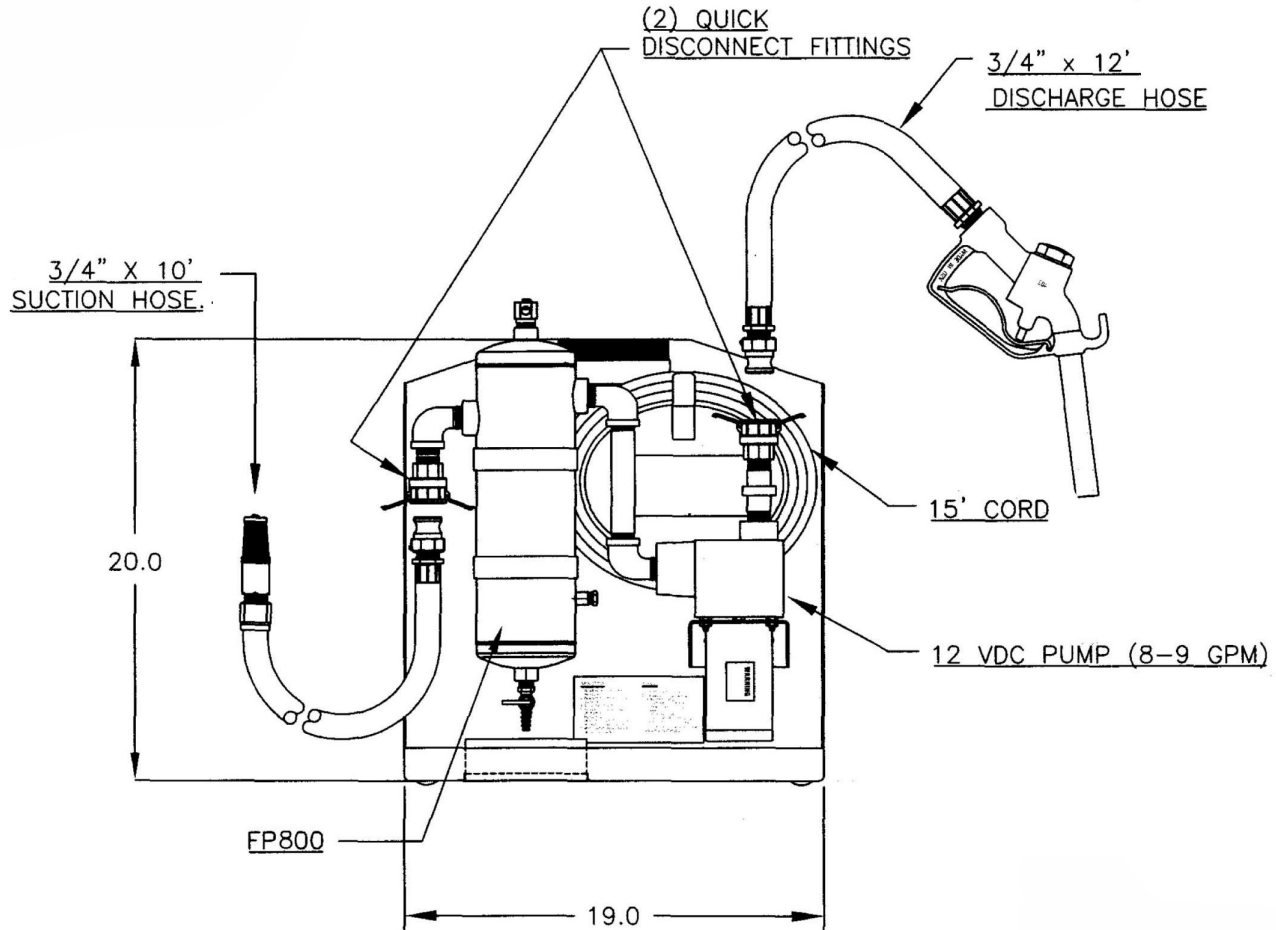

Product Details

Product Line	Portable Tank Cleaning Unit
Model	S/PTCU-8/X
Dimensions	20" H x 19" W x 15" D
Weight	45 lbs.

Hoses

Detachable Foot Suction Hose	10' x 3/4"
Detachable Foot Pressure Hose	12' x 3/4"
Manual Shut-Off Nozzle	3/4"
Quick-Release Aluminum Cam Lock Coupling	1" (2)

Pump and Motor

Standard Power	12 VDC, 60 Hz, Single Phase
Motor Horse Power	1/5
Motor Operation	Self-Priming
Max. Operating Pressure	78 psi
Pump Horse Power	1/5 hp
Pump Operation	Portable
Nominal Flow	8 gpm

Additional Features

- 90-Degree Swivel Couplings
- 15' Power Cord
- One Year Manufacturer's Warranty on pump

The Fuel Purifier

Model Number	TFP-800
Nominal Flow	8 gpm
Water Drain Port	1/2"
Free Water Removal	up to 99.8%
Contaminant Removal	up to 95%

