

The Marine Throne

"all the comforts of home"

Model TTM S/37045/X-Series

The Marine Throne Macerating Electric Toilet

FEATURES

- Very quiet flush cycle - like a household toilet
- Single button flush actuator - with dual function water level control switch
- Can be plumbed to any pressurized water system that can provide a 3-1/2 GPM (13.5 LPM) flow rate
- Water control solenoid valve with anti-siphon breaker to prevent contamination of potable water supply
- White vitreous china bowl available in compact or comfortable household size
- Baked enamel seat & cover - soft close seat option available on regular bowl models
- High capacity waste macerator and bowl discharge pump

SPECIFICATIONS

PORTS

Toilet Inlet 3/4" (19mm) Hose Barb
Toilet Outlet 1" (25mm) Hose Barb

MOTOR & SWITCH

Meet U.S.C.G. Regulation
183.410 and ISO 8846 MARINE **CE**
for Ignition Protection.

WATER CONSUMPTION

1-2 Quarts (Litres) per Flush

VARIATIONS AVAILABLE

MODEL NO.	DESCRIPTION
-----------	-------------

37045-3092	Compact Bowl 12V
-------------------	------------------

37045-3094	Compact Bowl 24V
-------------------	------------------

37045-4092	Regular Bowl 12V
-------------------	------------------

37045-4192	Regular Bowl 12V, Soft Close Seat/Lid
-------------------	---------------------------------------

37045-4094	Regular Bowl 24V
-------------------	------------------

37045-4194	Regular Bowl 24V, Soft Close Seat/Lid
-------------------	---------------------------------------

OPERATION

The Marine Throne toilet provides both quiet operation and user control of water levels in the toilet bowl. A single large push button switch provides a simple flush mode by activating both the rinse water supply and the macerator discharge pump simultaneously. An additional rocker switch offers independent control of the rinse water supply and discharge pump separately so the bowl water level can be easily raised or lowered by the user. This provides a method of minimizing water use, when desired, as well as a means of raising the water level in the bowl when appropriate for user comfort. It also allows for complete evacuation of the bowl water while underway in rough sea conditions.



INSTALLATION

PLUMBING

The toilet can be plumbed to any pressurized water system that can provide a minimum of 3-1/2 GPM (13.5 LPM). This may be a fresh water system including the vessel's potable water system or a washdown system utilizing either fresh or salt water. However, it must be connected to a pressurized system that normally remains on at all times while the vessel is in use.

To make the water connection, shut off the water system pump and open one of the systems faucets or fixtures to drain the pressure from the system. Select an appropriate tee type fitting that can be installed in the existing pressurized water system and will provide a 1/2" (13mm) hose barb to feed water to the toilet. Install the tee fitting at a location on the pressurized water system that provides convenient connection to the toilet's solenoid valve/ siphon breaker assembly. If the toilet is being connected to the vessel's fresh water system and the vessel may be connected to an unregulated city water supply, it is recommended that a valve be installed in the toilet water supply line ahead of the solenoid valve/siphon breaker to regulate the flow rate of incoming pressurized city water.

INSTALLATION (continued)

PLUMBING

The solenoid valve/siphon breaker should be positioned a minimum of six inches above the hose connection at the back of the toilet bowl (at all angles of heel and trim) and located as close to the toilet as possible. It should be located where an occasional drop or two of water from the siphon breaker will not adversely affect nearby equipment or supplies. It must be installed in a vertical position with the hose barb connections pointing down. The solenoid valve/siphon breaker bracket should be secured to a solid mounting surface with four screws. If the valve assembly is attached to a wood surface, 3/8" (10mm) long screws are generally adequate to support the weight of the valve assembly. If desired, the valve assembly may be installed inside a cabinet or locker to conceal it from view of the vessel's occupants. To provide a clean sanitary appearance inside the head area, a six foot section of smooth white hose is provided with the toilet to connect the toilet bowl spud fitting to the siphon breaker outlet hose barb.

The solenoid valve inlet hose barb is then connected with 1/2" (13mm) reinforced vinyl hose suitable for pressurized water to the tee fitting installed in the water system line. All pressurized water system connections should be secured with stainless steel band type hose clamps. The 3/4" hose connecting the siphon breaker to the bowl should be secured with a band clamp at the siphon breaker to prevent it from being accidentally dislodged but generally does not need a hose clamp to secure it to the bowl spud fitting unless desired for added security.

The discharge port includes a 1" (25mm) hose barb and should be plumbed with 1" (25mm) hose to an on board holding tank or, if appropriate, to an overboard discharge through hull. A 1" (25mm) to 1-1/2" (38mm) barbed hose adapter is provided to adapt a 1" (25mm) discharge hose

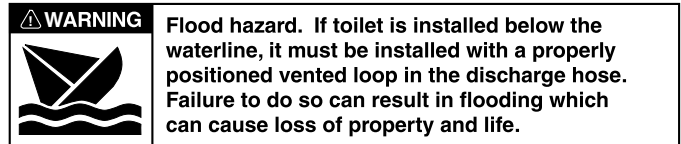

to 1-1/2" (38mm) hose, if desired. The discharge plumbing should be kept as short as possible and bends in the discharge hose should be kept to a minimum.

If the toilet is below the water line and is plumbed to an overboard discharge through hull, the discharge plumbing must include a vented loop positioned so it remains above the water line at all angles of heel and trim. Total discharge head should not exceed 4 feet (1.2m). To retain water in the bowl, the discharge hose should be looped upward about eight to ten inches above the base of the toilet and as near to the toilet as can be practically accomplished without creating an unsightly plumbing situation.

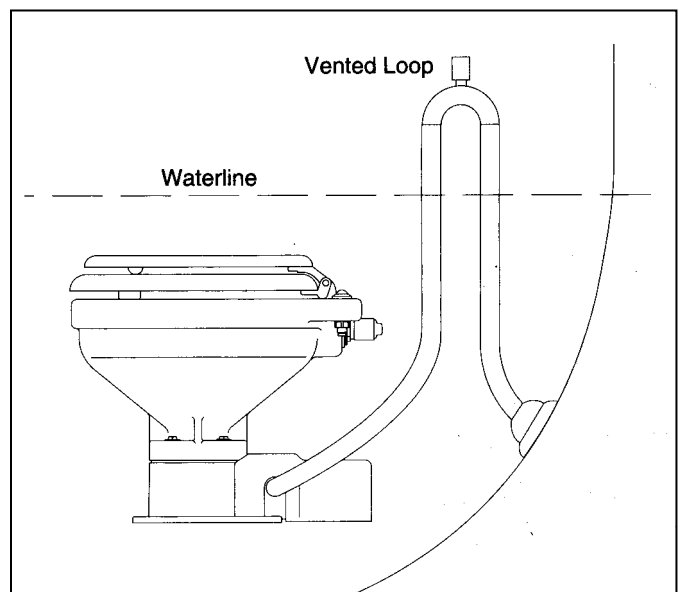

ELECTRICAL

The electrical wiring should be independent of all other accessories. It should be made with marine grade copper stranded wire of the gauge specified in the electrical specifications chart. Make all wire connections with mechanical locking type connectors (crimp type butt connectors and terminals). Ensure the circuit is protected by a proper sized fuse or circuit breaker determined from the electrical specifications chart. Secure all wires to a solid surface approximately every eighteen inches (1/2m) along their entire length of run.

Wire the switch panel to the solenoid valve/siphon breaker and toilet pump assembly as per the following wiring diagram. Select a location for the switch panel that is convenient to the toilet user and will also allow access to run the wires from the switch panel to both the toilet's motor and the solenoid valve/siphon breaker as well as

from the electrical power source to the switch panel. The red lead from the panel should be connected to an over-current protected positive power source. Connect the brown lead from the panel to the waste pump positive (orange) motor lead. Connect the black waste pump motor lead to battery negative. Connect the yellow lead from the panel to a solenoid valve terminal. Connect the remaining solenoid valve terminal to battery negative. The solenoid valve is not polarity sensitive.

To install the switch panel, drill two 1-3/4" (45mm) diameter holes (slightly over-lapping) through the selected switch mounting surface per the attached template. Ensure the template is oriented correctly because it is not symmetrical. Also, drill four appropriate sized holes for the fasteners selected to secure the switch panel to its mounting surface.

ELECTRICAL SPECIFICATIONS

Voltage	Amp Draw	Fuse Size	Wire Size Per Feet Of Run*				
			0'-10'	10'-15'	15'-25'	25'-40'	40'-60'
12 Vdc	10	25	#16	#14	#12	#10	#8
24 Vdc	5	15	#16	#16	#16	#14	#12

* Length of run is total distance from power source to product and back to ground.

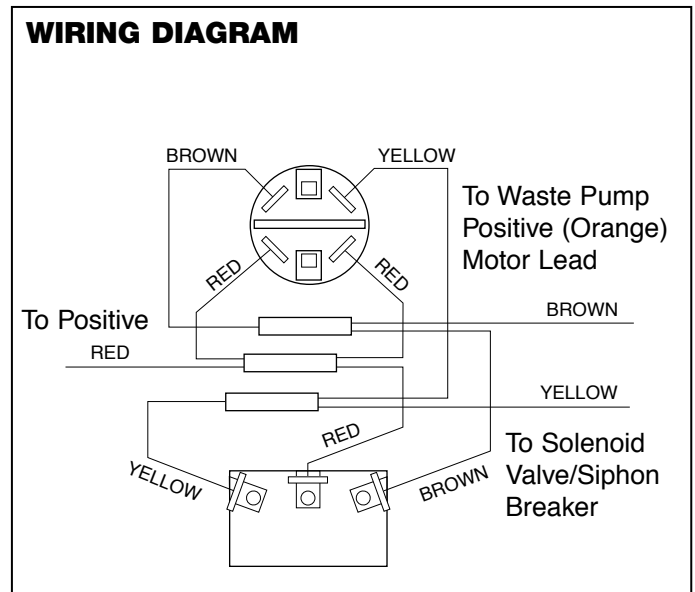
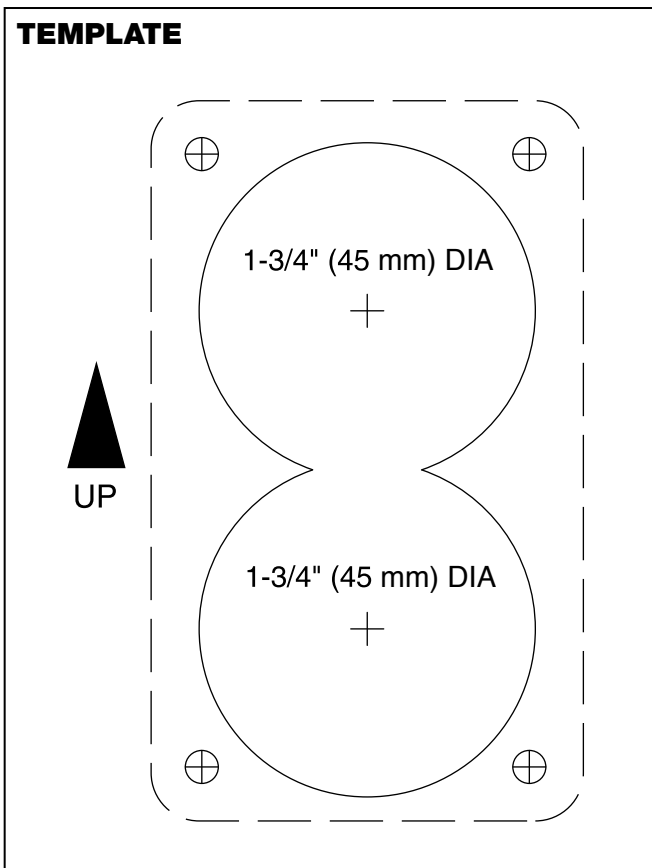

SERVICE

The SkimOil Marine Throne Toilet does not require routine maintenance other than occasional cleaning to maintain a hygienic sanitary condition. Clean toilet with mild nonabrasive cleaners without strong aromatics. Cleaners having high concentrations of aromatics such as pine scented concentrated cleaners and strongly scented degreaser concentrates can cause the pump's seal to swell and may contribute to a premature seal leak.

The toilet has no wearing parts that need periodic replacement other than the shaft seal which, under normal conditions, should provide several years of service before needing replacement. The seal only requires replacement if signs of leakage are noticed under the seal housing positioned between the motor and toilet base assembly.

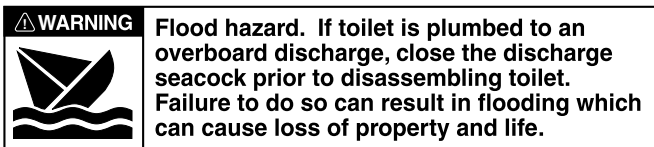

Notice: Before performing any service, disconnect the power supply to the toilet and take precaution to ensure it is not reconnected until the service is complete. Also, pump all water from the toilet bowl and if connected to an overboard discharge, close the discharge seacock.

To replace the shaft seal, snap off the white motor cover and remove the pump assembly by removing the four screws with lock washers that secure it to the toilet base. Carefully slide the pump assembly from the base ensuring the macerator housing also slides out of the base with the pump.

The pump chopper will engage the macerator housing and it may be necessary to gently tap the chopper against the macerator housing to free it from the base.

Prevent the motor shaft from turning by inserting a screwdriver in the shaft slot at the rear of the motor and unscrew the nut retaining the chopper blade. Remove the chopper and macerator housing from the motor shaft. Remove the O-ring from the O-ring groove around the outer diameter of the seal housing. With an allen wrench, loosen the centrifugal impeller set screw and slide the impeller off the shaft. Remove the two screws that secure the seal housing to the motor and slide the housing off the motor shaft. Remove the two seal washers from under the head of each of the two seal housing retainer screws. With a pair of needle nose pliers grasp the shaft seal and pull it from the seal housing. Clean all parts and inspect for damage.

Lubricate the OD of the new seal with a small amount of water and press it into the seal bore with the seal's lip facing the threaded end of the shaft. Do not use the stainless steel star retaining washer supplied with the seal. Lubricate the ID of the seal and the motor shaft with a small amount of water resistant grease. Ensure the slinger is properly positioned on the motor shaft next to

the motor and slide the seal housing onto the motor shaft until it is against the motor end bell. Position a new plastic seal washer under the head of each of the flat head seal housing retainer screws and secure the seal housing to the motor. Slide the centrifugal impeller on the motor shaft positioning it about 1/32" (1mm) from the seal housing and secure it to the shaft with the set screw. Rotate the impeller to ensure it does not rub on the seal housing.

Slide the macerator housing over the motor shaft, place the lock washer on the end of the shaft and screw the chopper onto the shaft. Tighten the chopper while holding the motor shaft at the rear of the motor. Position a new O-ring in the seal housing O-ring groove (it may be retained in the groove with a small amount of grease). Slide the pump assembly into the toilet base ensuring the macerator housing is properly positioned within the base. The cut-out in the side of the macerator housing must align with the discharge port in the base (the macerator housing is keyed so it will only go in when properly positioned). Ensuring the O-ring is still properly positioned in the O-ring groove in the seal housing, place the pump assembly against the base and secure it in place with the four screws and lock washers. Replace the white motor cover by snapping it down over the pump motor.

EXPLODED VIEW

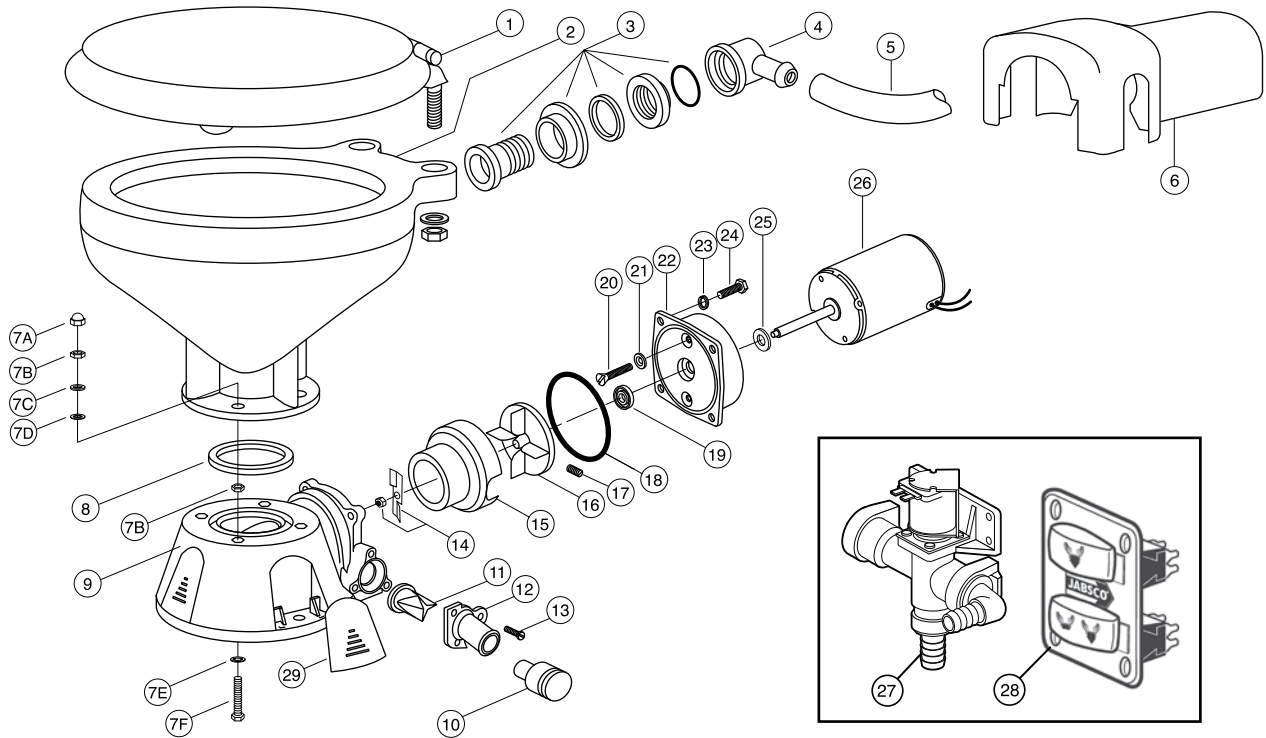

PARTS LIST

Key	Description	Qty. Req.	Part Number	Key	Description	Qty. Req.	Part Number
1.	Seat & Cover			17	Set Screw †	1	91084-0320
	Note - 2016 models identified with Jabsco logo on top of bowl.			18	O-ring* †	1	43990-0066
	Compact	1	29097-1000	19	Seal* †	1	1040-0000
	Regular (Pre 2018)	1	29127-1000	20	Screw †	2	91010-0144
	Regular (2018 onwards)	1	58104-1000	21	Washer, Plastic* †	2	35445-0000
	Soft Close (2018 onwards)	1	58104-2000	22	Seal Housing †	1	37043-1000
2.	Bowl			23	Lock Washer #10, Stainless Steel †	4	
	Compact	1	29096-1000	24	Screw †	4	91027-0011
	Regular	1	29126-1000	25	Slinger †	1	6342-0000
3.	Hinge Set (1 PAIR)			26	Motors:		
	Compact (ALL VARIANT)	1	29098-1000		Motor - 12 Volt †	1	18753-0554
	Regular (Pre 2018)	1	29098-2000		Motor - 24 Volt †	1	18753-0555
	Regular (2018 onwards)	1	58105-1000	27	Solenoid Valve & Siphon Breaker		
	Soft Close (2018 onwards)	1	58105-2000		12 Volt	1	37038-1012
3 & 4	Bowl Spud & Intake Elbow & O-ring	1	29048-0000		24V	1	37038-1024
5	Hose, 6 feet	1	29035-1031	28	Switch Panel	1	37047-2000
6	Motor Cover	1	37042-1000	29	Screw Covers (3/kit)	1	37003-0000
7	Bowl Installation Hardware	1	18753-0637		Service Kit		90197-0000
7A	Nut Cap**	4			Motor & Pump Assembly		
7B	Hex Nut** (Two places)	8			12 Volt		37072-0092
7C	Washer, Stainless Steel**	4			24 Volt		37072-0094
7D	Washer, Plastic**	4					
7E	Washer, Starlock**	4					
7F	Phillips Head Screw**	4					
8	Bowl O-Ring Seal	1	44101-1000				
9	Base Assembly**	1	37004-1000				
10	1-1/2" Adapter, Discharge Port	1	98023-0080				
11	Joker Valve* **	1	44106-1000				
12	1" Discharge Port**	1	44107-1000				
13	Screw**	3	96050-0568				

* Parts Supplied with Service Kit.

** Parts included with base 37004-1000.

† Parts included in Motor & Pump Assembly.

DIMENSIONAL DRAWING
Inches (Millimetres)

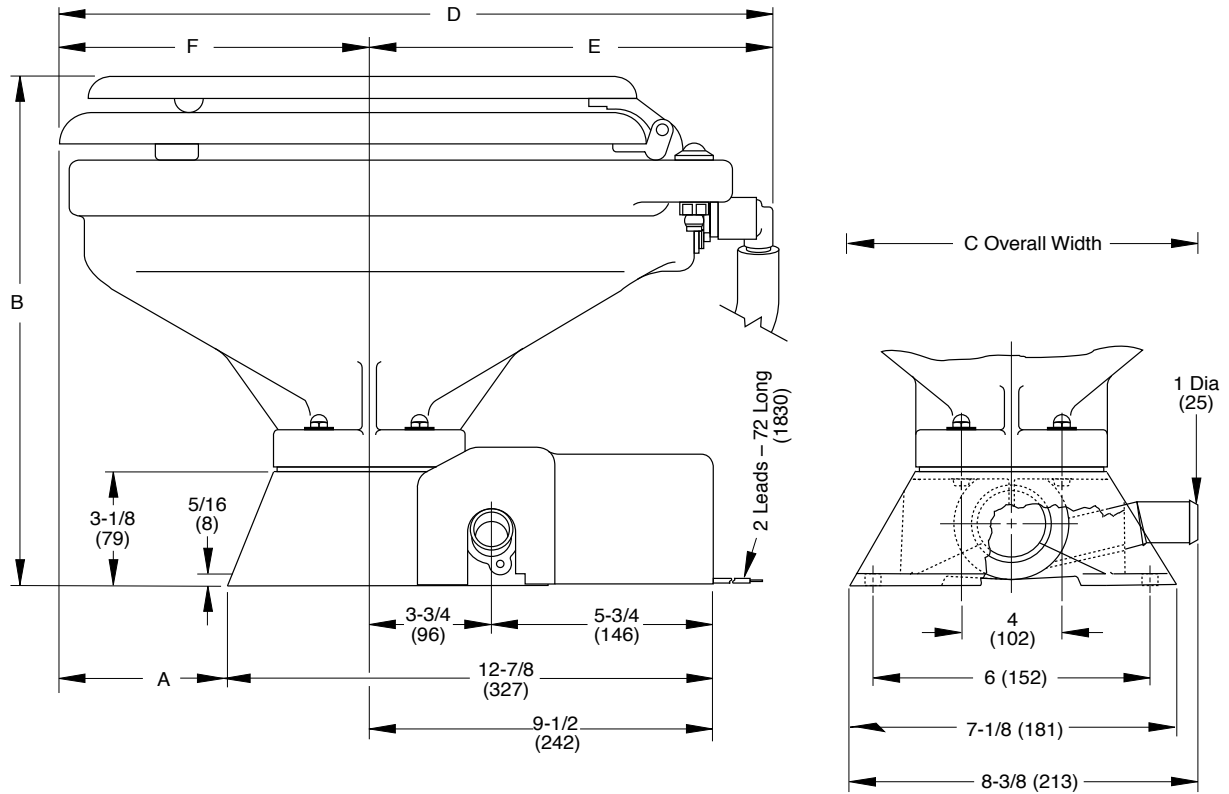

	A	B	C	D	E	F
Compact Size Bowl	3-2/8 (83)	14 (355)	13-1/8 (333)	16-3/8 (415)	9-7/8 (250)	6-7/8 (175)
Household Size Bowl	4-2/8 (108)	14-3/8 (365)	14-3/4 (375)	18-7/8 (480)	10-5/8 (270)	8-2/8 (210)